

gamma/ L

Solenoid-driven diaphragm metering pump

A calibratable pump for the most exacting output requirements, universally controllable, with BUS interface.

- Capacity range
0.74–32 l/h, 16–2 bar
- Direct adjustment and monitoring of the dosing capacity on a plain text display help prevent incorrect dosing
- Cost and space savings through integral 2-week process timer
- Clearly readable figures thanks to large illuminated LC display
- Simple and straightforward connection to complex process control systems thanks to optional configuration with PROFIBUS® DP interface
- Input for level switch

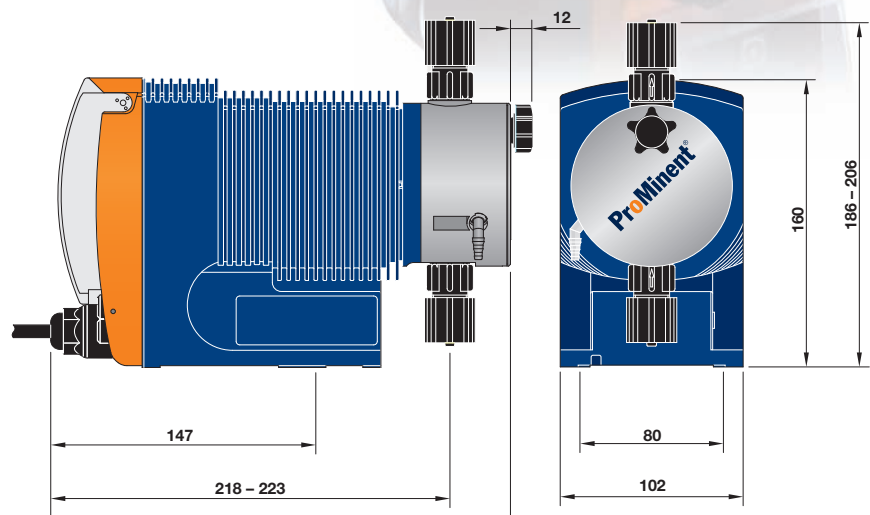

gamma/ L

Pump type	Delivery rate at max. backpressure		Nr. of strokes strokes/min	Connection size o Ø x i Ø mm	Suction head mWC	Average power consumption W	
	bar	l/h					ml/stroke
GALa 1000	10	0.74	0.07	180	6 x 4	6.0	17
GALa 1601	16	1.10	0.10	180	6 x 4	6.0	17
GALa 1602	16	2.10	0.19	180	6 x 4	6.0	17
GALa 1005	10	4.40	0.41	180	8 x 5 ¹⁾	6.0	17
GALa 0708	7	7.10	0.66	180	8 x 5	6.0	17
GALa 0413	4	12.30	1.14	180	8 x 5	3.0	17
GALa 0220	2	19.00	1.76	180	12 x 9	2.0	17
GALa 1605	16	4.10	0.38	180	8 x 5 ¹⁾	6.0	23
GALa 1008	10	6.80	0.63	180	8 x 5	6.0	23
GALa 0713	7	11.00	1.02	180	8 x 5	4.0	23
GALa 0420	4	17.10	1.58	180	12 x 9	3.0	23
GALa 0232	2	32.00	2.96	180	12 x 9	2.0	23

gamma/ L metering pumps are also available with self-degassing liquid end and for highly viscous media.

Suction lift readings when liquid end and suction tubing are full, or for self-degassing liquid end when the suction tubing contains air.

1) 6 mm inner diameter in stainless steel version.

Materials in contact with medium

Material	Liquid end	Suction/pressure port	Seals	Valve balls
PPT	Polypropylene	PVDF	PTFE	Ceramic
NPT	Acrylic glass	PVDF	PTFE	Ceramic
PVT	PVDF	PVDF	PTFE	Ceramic
TTT	PTFE with carbon	PTFE with carbon	PTFE	Ceramic
SST	Stainless steel Mat. Nr. 1.4404	Stainless steel Mat. Nr. 1.4404	PTFE	Ceramic

DEVELOPAN® metering diaphragm with PTFE coating for all types.